

UCP
PAYMENT SPECIALISTS

**wh münzprüfer
berlin** gmbh

wh Münzprüfer Berlin

CIS 100 / CIF 100 Coin Feeder



Bulk Coin Insertion System

Automated coin separation system

High capacity insertion bowl

EMP800 coin acceptor

Intermediate coin storage

Distributed by:

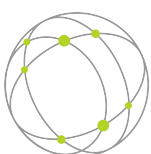

UCP
PAYMENT SPECIALISTS

UCP Inc.
www.ucp-inc.com

7200 W Post Rd Suite 100, Las Vegas, NV, 89113

Tel.702-802-3504 Email.
info@ucp-inc.com

For Automated Cash Systems

Designed for the automatic handling of coins in cashier systems in retail applications, the CIS100 system incorporates a collecting pan in which the customer may drop a mixture of coins. The CIS100 separates the coins and feeds them to the coin validator system consisting of the coin selector frame, electronic coin acceptor and electronic motor reject. All components are controlled via ccTalk interface. Float mounting of the coin insertion system ensures optimum performance and reliability.

Modular Integration

The design of the coin separation system allows the modular integration in money handling systems with hoppers for dispensing change. The host system controls the coin separation system with respect to specific commands and status messages via the serial interface. The coin insertion process may be terminated at any time by activating the motor driven opening mechanism of the coin feeder. Remaining coins and possible foreign objects will be returned to the customer. The approximate coin processing speed is between 1.6 and 2.0 coins per second.

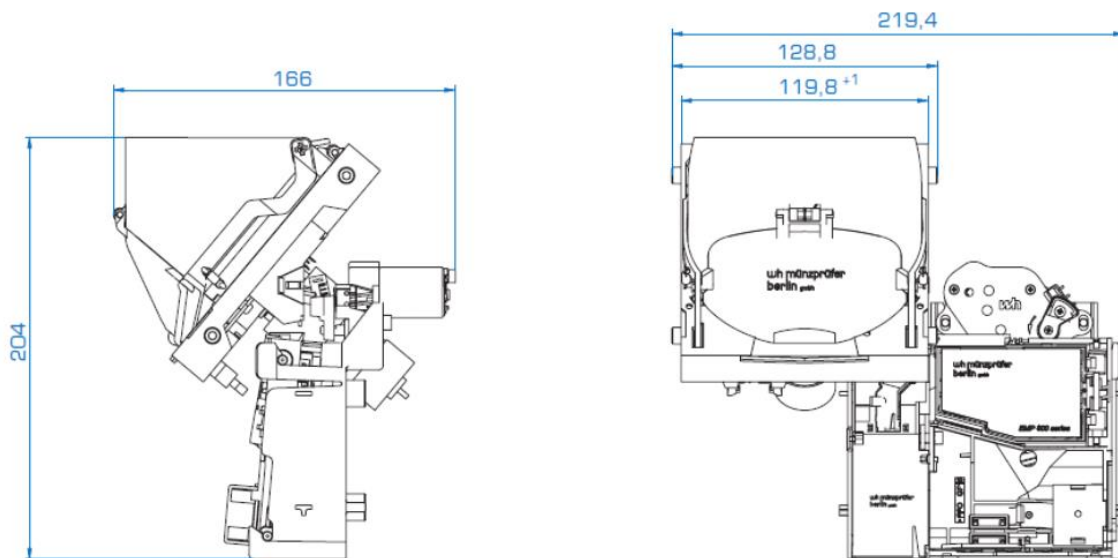

Distributed by: